

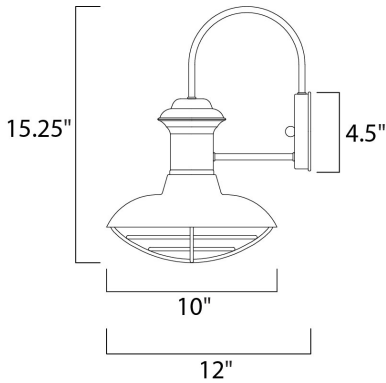

PRODUCT DESCRIPTION

Wharf is a transitional style collection from Maxim Lighting International, available in multiple finishes.



MEASUREMENTS

DIMENSION : 10." W x 15.25" H x 12." Ext
 BACK PLATE : 4.5" W x 4.5" H x 8." HCO
 HANGING WEIGHT : 2.2 lb

LAMPING

INPUT VOLTAGE : 120V
 LUMENS : 0 Rated (0 Del.)
 BULB : 1 x 60W (NOT INCLUDED), 60W Total
 DIMMABLE : Dimmable

FINISHES OPTION

Oriental Bronze OB



MATERIAL

Aluminum

RATINGS

cETLusWet Location
 Dimmable



ADDITIONAL

INSTALL UP/DOWN:
 OPERATING TEMPERATURE:
 -20°C (-4°F), 40°C (104°F)

Always consult a qualified electrician before installing any lighting product.



WESTERN DISTRIBUTION CENTER (HEADQUARTER)
 253 NORTH VINELAND AVE | CITY OF INDUSTRY, CA 91746

EASTERN DISTRIBUTION CENTER
 4200 SHIRLEY DR. | ATLANTA, GA 30336

P. 626.956.4200 | F. 626.956.4225 | maximlighting.com